

ENGINE

Model	Case 432T / M3
Type	Diesel 4-stroke, Turbo, D.I.
Cylinder	4
Bore/stroke	3.9 x 4.1 in (99 x 104 mm)
Displacement	195 cu in (3.2 L)
Fuel injection	Direct
Fuel	#2 diesel
Fuel filter	In-line strainer
Air intake	Turbocharged w/ external EGR
Cooling	Liquid
Engine speeds	
High idle - no load (rpm)	2675 +/- 75
Rated -full load (rpm)	2500
Low idle (rpm)	1075 +/- 75
Horsepower per SAE J1349	
Gross	90 hp (67 kW) @ 2500 rpm
Net	84 hp (63 kW) @ 2500 rpm
Peak torque	251 lb-ft (340 Nm) @ 1400 rpm

ENGINE COOLING

Radiator –	
Core type	All aluminum
Core size area	0.266 m ²
Rows of tubes	42
Cap pressure	16 +/-2 psi
Fan –	
Diameter	20.4 in (518 mm)
Ratio	0.96:1
Water pump	
Style	Centrifugal
Flow	29 gpm (110 L/min)
Engine lubrication	
Pump	Rotor pump w/ deep sump pan, plate cooler, and pressurized under-piston nozzles
Pump operating angle ratings	
Side to side	45°
Bucket up	35°
Bucket down	45°
Oil filtration	Replaceable, full-flow cartridge

POWERTRAIN

Drive pump – Mechanical	
Pump to engine ratio	1:1
Displacement cc (cu in)	2.81 cu in (46 cc)
Flow at rated engine rpm	
@100% efficiency	30.4 gpm (115 L/min)
Charge Pressure	363 psi (25 bar)
System relief	5,220 psi (360 bar)
Control	Mechanical servo
Drive pump – Electro Hydraulic	
Pump to engine ratio	1:1
Displacement cc (cu in)	2.81 cu in (46 cc)
Flow at rated engine rpm	
@100% efficiency	30.4 gpm (115 L/min)
Charge Pressure	363 psi (25 bar)
System relief	5,220 psi (360 bar)
Control	Electro Hydraulic
Drive motors	
Max. displacement	28.68 cu in (470 cc)
Displacement - optional	
high speed	17.21 cu in (282 cc)
Speed @ high idle engine rpm	
(100% eff. at rated engine rpm)	244
Speed @ optional high speed rpm	408
Torque @ max displacement and relief pressure (calculated, 345 bar)	2,694 lb-ft (1987 N-m)
Travel speed –	
Low range	7.2 mph
High range (optional)	11.9 mph
Final drive	Single-reduction chain drive
Drive chain –	
Size	ASA #100
Tensile strength	30,000 lb (133.4 kN)
Axles –	
Torque @ max. displacement and relief pressure	6,623 lbf -ft (8980 N-m)
Diameter	2.44 in (61.94 mm)
Length	15.7 in (398.7 mm)
Parking brake	
Type	Spring-applied, hydraulic release disc
Engagement	Depress on/off brake button on handle or instrument panel, raise seat bar, get off seat, or stop engine

HYDRAULIC SYSTEM

Standard equipment pump –	
Type	Gear
Displacement –	
Standard Aux.	2.08 cu in (34.1 cc)
High Flow Aux.	1.12 cu in (18.3 cc)
Pump flow @ rated engine rpm	
@ 100 % efficiency	22.5 gpm (85 L/min)
Optional high flow @ rated engine rpm	
@ 100 % efficiency	12.1 gpm (46 L/min)
Loader control valve –	
Type	3 Spool / Open Center / Series
Relief pressure	3,000 psi (207 Bar)
Port relief pressures –	
Loader raise	3,263 psi (225 bar)
Bucket dump	3,481 psi (240 bar)
Bucket curl	3,336 psi (230 bar)
Hydraulic lines –	
Tubing	37° JIC Flare
Loop hoses	SAE 100 R13
Hydraulic oil cooler –	
Number of fins	10 per inch (3.94 per cm)
Number of Tubes	11
Area	130.7 sq in (843 cm ²)
Hydraulic filter	6 micron / Spin on

INSTRUMENTATION

Indicators
Digital Hourmeter
Fuel level LCD bar graph with alarm
Warning lights with alarms
Engine coolant temperature
Engine oil pressure
Engine Malfunction
Hydraulic charge pressure
Hydraulic filter restriction
Hydraulic oil temperature
Warning alarms
Battery voltage (plus display)
Indicator light
Engine preheat
Parking brake
Seat bar reminder

ELECTRICAL SYSTEM

Alternator 95 amp
Starter 4.0 kW
Battery
12-volt low-maintenance 1000 cold-cranking amps @ 0° F (-18° C)

OPERATOR ENVIRONMENT

ROPS/FOPS level 1 canopy w/side screens
Tilt ROPS/FOPS
Rear window w/ emergency escape
Instrument panels
Suspension vinyl seat
2 in (51 mm) retractable seat belt
Hand throttle
Foot throttle
Alarm package
Headliner
Top window
Cup holder
Power plug socket
Foot rest
Storage tray
Low effort ergonomic hand controls
Padded seat bar w/integral armrests
Loader control lockout system
Electric parking brake control
Floor cleanout panel

CYLINDERS

Lift cylinder –	
Bore diameter	2.5 in (63.5 mm)
Rod diameter	1.75 in (44.5 mm)
Stroke	32.2 in (817.9 mm)
Closed length	45.6 in (1158.0 mm)
Bucket cylinders –	
Bore diameter	3.0 in (76.2 mm)
Rod diameter	1.5 in (38.1 mm)
Stroke	16.1 in (410.0 mm)
Closed length	24 in (610.0 mm)

WEIGHTS

Operating weight	7,700 lb (3490 kg)
Shipping weight	7,365 lb (3340 kg)
Add-on weights –	
Side cab glass	46.9 lb (21.3 kg)
Lexan door	74 lb (33.6 kg)
Glass door with wiper	134 lb (60.8 kg)
Suspension seat	22.1 lb (10 kg)

SERVICE CAPACITIES

Fuel tank	25.5 gal (96.5 L)
Engine oil with filter	10.5 qt (10 L)
Hydraulic system –	
Reservoir	5.9 gal (22.4 L)
Total	NA
Chain tanks (per side)	7.8 qt (7.4 L)

TIRE SELECTION

	Size	Ply Rating	Tread Depth	Tire Width	Tread Width	Width Over Tires	Tire Weight*
Heavy-Duty	12 x 16.5	–	–	–	57 (1465)	70 (1785)	–
Premium	12 x 16.5	–	–	–	57 (1465)	70 (1785)	–
Premium-Lined	12 x 16.5	–	–	–	57 (1465)	70 (1785)	–
Severe Duty	12 x 16.5	–	–	–	57 (1465)	70 (1785)	–
Mining	12 x 16.5	–	–	–	57 (1465)	70 (1785)	–
Non-Pneumatic	12 x 16.5	–	–	–	57 (1465)	70 (1785)	–
Flotation	33 x 15.5	–	–	–	60 (1544)	76 (1930)	–
Premium	14 x 17.5	–	–	–	62 (1579)	76 (1930)	–

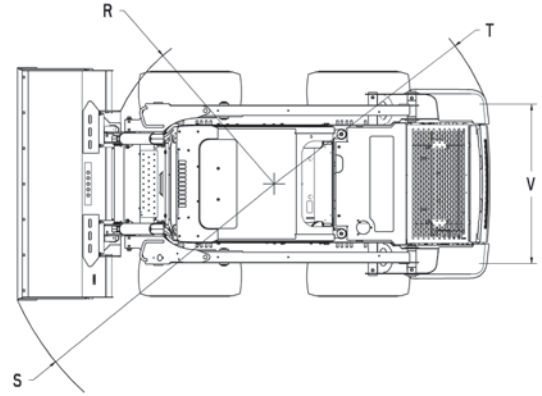
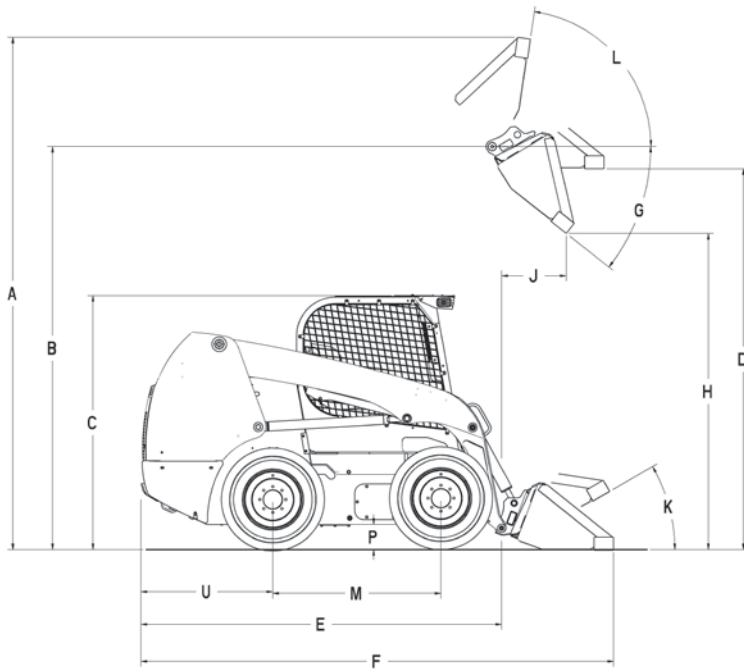

DIMENSIONS

A. Overall operating height - in (m) –	
with foundry/excavating bucket short lip	156.3 (4.0)
with low profile/standard lip bucket	160.3 (4.1)
with low profile extended / long lip bucket	165.3 (4.2)
Height to - in (m) –	
B. Bucket hinge pin	125 (3.2)
C. Top of ROPS	78.8 (2.0)
D. Bottom of level bucket, fully raised	118 (3.0)
Overall length - in (m) –	
E. without attachment with coupler	117.1 (3.0)
F. with foundry excavation bucket on ground	142.2 (3.6)
with low profile bucket.	146.2 (3.7)
with low profile extended bucket.	151.3 (3.8)
G. Dump angle.	38.3°
H. Dump height - in (m) –	
with foundry/excavating bucket short lip	100.7 (2.6) @ 38.3°
with low profile/standard lip bucket	98.1 (2.5)
J. Dump reach (max. height) - in (m)	19.5 (0.5)
Maximum attachment rollback –	
K. Bucket on ground	30.7°
L. Bucket at full height.	99.7°
M. Wheelbase - in (m)	52 (1.3)
P. Ground clearance (bottom of belly pan) - in (m)	8 (0.2)
Q. Angle of departure	23.5°
Clearance circle - in (m) –	
R. without bucket.	55.1 (1.4)
S. with 72-inch (1.8 m) foundry bucket in carry position	84.2 (2.2)
with 72-inch (1.8 m) low profile bucket on ground	87.2 (2.2)
with 72-inch (1.8 m) extended low profile on ground	91.9 (2.3)
T. Clearance circle rear - in (m)	70.4 (1.8)
U. Rear axle to bumper - in (m)	40.7 (1.0)
Rolling radius - in (m)	16.1 (0.4)
V. Tread width with spec tires - in (m) –	57.7 (1.5)
Over the tire width with spec tires - in (m) –	70.28 (1.8)

PERFORMANCE SPECS

Rated operating load –	
50%	2,500 lb (1135) kg
Tipping load	5,000 lb (2268) kg
Breakout forces (calculated @ 3150 psi) –	
Lift cylinder	6,125 lb (27.2) kN
Bucket cylinder	8,585 lb (38.2) kN
Cycle Times (seconds)–	
Raise	3.7
Lower	1.9
Dump	2.7
Roll back	2.0

OPTIONAL BUCKETS

Type	Width inch (m)	Weight lb (kg)	Heaped Capacity ft ³ (m ³)
Dirt & Foundry	72	390	16.7
	(1.8)	(177)	(0.47)
	78	435	18.4
	(2.0)	(197)	(0.52)
Low Profile	72	425	14.5
	(1.8)	(193)	(0.41)
Low Profile Extended	72	477	17.1
	(1.8)	(216)	(0.48)
	78	502	18.6
	(2.0)	(228)	(0.53)
	84	607	20.2
	(2.1)	(275)	(0.57)
Light Material	72	434	23.7
	(1.8)	(197)	(0.67)
	84	497	27.9
	(2.1)	(225)	(0.79)
Manure & Slurry	72	465	19.1
	(1.8)	(211)	(0.54)
	84	535	22.5
	(2.1)	(243)	(0.64)
Heavy Duty	72	501	14.6
	(1.8)	(227)	(0.41)
	78	527	15.9
	(2.0)	(239)	(0.45)
	84	550	19.4
	(2.1)	(249)	(0.55)

STANDARD EQUIPMENT

OPERATOR'S COMPARTMENT

ROPS/FOPS level 1 canopy w/side screens
Tilt ROPS/FOPS
Rear window w/ emergency escape
Instrument panels
Suspension vinyl seat
2 in (51 mm) retractable seat belt
Hand throttle
Foot throttle
Alarm package
Headliner
Top window
Cup holder
Power plug socket
Foot rest
Storage tray
Low effort ergonomic hand controls
Padded seat bar w/integral armrests
Loader control lockout system
Electric parking brake control
Floor cleanout panel

LOADER

Radial loader arm design
Mechanical attachment coupler
Loader lift arm support strut

ENGINE

Case/Iveco 432T/M3 diesel
No maintenance belt
Over & under radiator and oil cooler
Glow plug
Integral engine oil cooling
Fuel filter w/water trap
Dual element air cleaner
95 amp alternator
1000 CCA 12-volt battery

POWERTRAIN

Hydrostatic four wheel drive
Servo controlled pumps
ASA #100HS drive chain
SAHR disc parking brakes

HYDRAULICS

Auxiliary hydraulics 3050 psi
(210 bar) – 23.8 gpm (90 L/min)
Hydraulic circuit pedal lock
Loader arm-mounted ISO flat face connectors
Auxiliary function lockout override
Loader function lockout system
Loader lift lockout override
3-spool loader control valve
Heavy-duty oil cooler
Loader arm float position

OTHER

2 speed transmission
Add-on counterweights
Lockable service access hood
Single-point daily servicing
Halogen lights, 2-front, 2 side, 2-rear (halogen)
Rear tail lights
Remote oil drain

OPTIONAL EQUIPMENT

OPERATOR'S COMPARTMENT

Deluxe cloth suspension seat w/ heater and lumbar support
Interior mirror
Electric auxiliary hydraulic control
Glass front door w/wiper & washer
Sliding side windows
3 inch retractable seat belt
Heater and AC
Radio
Demolition door

LOADER

Auxiliary front electric control
Ride control
Switchable EH controls
Hydraulic attachment coupler
Hydraulic one-way self-leveling

HYDRAULICS

High-flow auxiliary hydraulics
3050 psi (210 bar) – 33.2 gpm (126 L/min)
Second auxiliary hydraulics
Attachment case drain plumbing

ENGINE

Coolant block heater
Battery disconnect switch

OTHER

Deluxe instrument panel
Road lights
Rotating beacon
Lift hooks
Special paint
Language decals
Factory-installed tires – see page 2
Buckets – see page 3
Bolt-on bucket cutting edges
42 in (1.07 m) and 48 in (1.22 m) pallet forks
Steel tracks



NOTE: All specifications are stated in accordance with SAE Standards or Recommended Practices, where applicable.

NOTE: All engines meet current EPA emissions requirements.

IMPORTANT: Case Construction Equipment Inc. reserves the right to change these specifications without notice and without incurring any obligation relating to such change. Case Construction Equipment Inc. does not warrant the safety or reliability of attachments from other manufacturers.

Case is a registered trademark of CNH America LLC. Any trademarks referred to herein, in association with goods and/or services of companies other than CNH America LLC, are the property of those respective companies.

Form No. CCE201009SR250
Replaces form no. None

Printed in U.S.A.
SR250 • Page 4 of 4



www.casece.com

© 2010 CNH America LLC
All Rights Reserved



All Case construction equipment is biodiesel ready.