

### ENGINE

Model	Case 445TA/E3 diesel, emissions certified
Type	4-stroke, turbocharged
Cylinders	4
Bore/Stroke	4.09 in x 5.19 in (104 x 132 mm)
Displacement	274 in <sup>3</sup> (4.5 L)
Fuel injection	Direct high pressure common rail (HPCR)
Fuel	Diesel
Fuel filter	w/water trap
Air intake	Cross-flow
Cooling	Liquid
Engine speeds* (rpm)	
Rated speed, full load	2200
Low idle	900 - 1000
High idle, no load	2330 - 2430
Horsepower	
Gross	97 (72 kW) @ 2200 rpm
Net w/viscous fan**	95 (71 kW) @ 2200 rpm
Net	92 (68 kW) @ 2200 rpm
Maximum torque @ 1400 rpm	
Gross	334 lb-ft (453 N-m)
Net w/viscous fan**	333 lb-ft (452 N-m)
Net	328 lb-ft (445 N-m)
Torque rise at rated speed	45%

NOTE: \*Engine speeds with standard transmission. Meets federal emission regulations.  
 \*\* Viscous fan included with Cab Convenience package.

### ENGINE COOLING

Radiator	
Core size area	486 in <sup>2</sup> (3145 cm <sup>2</sup> )
Rows of tubes / with AC	3 / 5
Fan	
Style	7 blade suction
Diameter	19.65 in (499 mm)
Angle - Std./Opt.	33°/39°
Ratio	1.1:1
Water pump	
Style	Integral

Engine oil	
Pump	Deep sump plate cooler with pressurized under-piston nozzles
Pump operating angle ratings	
Side-to-side	Rated 35°
Fore and aft	Rated 35°
Oil filtration	Replaceable, full-flow cartridge

### TIRES

Front	
2WD - 11L x 16, 10-ply rating	
4WD - 12 x 16.5, 8-ply rating	
Rear	
2/4WD - 19.5L x 24, 10-ply rating	
2/4WD - 17.5L x 24, 10-ply rating	

### POWERTRAIN

Transmission - standard	
4F-4R Power Shuttle Synchronesh transmission manual gear shift fully synchronized	

### POWERTRAIN (CONTINUED)

Transmission - optional  
 Powershift S-Type, 4F-3R fully synchronized

Specifications below apply to both Power Shuttle and Powershift S-Type transmission unless otherwise indicated.

Gear ratios	Forward	Reverse
1st	5.603	4.643
2nd	3.481	2.884
3rd	1.584	1.313
4th	0.793	0.657*

\*4R not available on Powershift S-Type

Travel speeds - mph (km/h)				
	1st	2nd	3rd	4th
Forward	3.8 (6.1)	6.0 (9.7)	12.8 (20.6)	24.0 (38.6)
Reverse	4.5 (7.3)	7.2 (11.6)	15.4 (24.7)	28.8* (46.3)

NOTE: Travel speeds at 2293 engine rpm with 19.5 x 24 tires. Speeds decrease with 17.5L x 24 rear tires. 4R not available on Powershift S-Type

Transmission - optional		
Powershift H-Type, 4F-3R hydraulic clutch shifting with auto function		
Gear ratios	Forward	Reverse
1st	5.533	4.549
2nd	3.359	2.762
3rd	1.533	1.260
4th	0.811	-

Travel speeds - mph (km/h)				
	1st	2nd	3rd	4th
Forward	3.9 (6.2)	6.3 (10.1)	13.3 (21.4)	23.6 (38.0)
Reverse	4.6 (7.4)	7.5 (12.1)	16.0 (25.7)	-

NOTE: Travel speeds at 2312 engine rpm with 19.5 x 24 tires. Speeds decrease with 17.5L x 24 rear tires.

Torque converter ratio	2.6
Differential lock	On-the-go push-button activation
Front 4WD / Rear axle	
Differential ratio	2.0 / 2.5
Planetary hub ratio	6.0 / 6.4
Total reduction ratio	12.0 / 16.0

Service brakes	Individually applied, power assisted, hydraulically actuated, maintenance-free, self-adjusting, outboard mounted, wet disc, 2 per side
Disc area	384 in <sup>2</sup> (25 m <sup>2</sup> )

Parking brakes	Trans Mounted spring applied hydraulic release (SAHR)
----------------	---

### ELECTRICAL

Voltage	12 volts, negative ground
Alternator	120 amp
Battery	850 cold-cranking amps

### ELECTRICAL (CONTINUED)

Optional batteries	(2) 850 cold-cranking amps
Power plugs	(2) 30 amps total

### HYDRAULICS

Pump	Bosch Rexroth Series 31 Variable Displacement Axial Piston Pump
Main relief pressure	
Standard	3450 +/- 50 psi (238 +/- 3.5 bar)
Power Lift	3625 +/- 50 psi (250 +/- 3.5 bar)
Filtration	7-micron, full flow replaceable cartridge on return line, condition indicator light for filter
Oil cooler	Heavy-duty
Loader flow @ rated engine rpm	40 GPM @ 2340 PSI (151.4 lpm @ 161 bar)

### Loader control valve w/pilot or manual backhoe controls

Two or three spool closed center sectional control valve. Single lever manual control for lift and tilt functions. The three spool valve uses a proportional Electro-Hydraulic control for the auxiliary function. The lift lever has a positive hold "Float" position and a "return-to-dig" feature.

Loader auxiliary hydraulics with proportional thumb switch w/detent on loader control handle 0 to 31.5 gpm (0 to 119 L/min)

Backhoe flow @ rated engine rpm  
 40 GPM @ 3100 PSI (151.4 lpm @ 161 bar)

### Manual Backhoe Control Valve

Six or seven monoblock open center control valve. Features "Pro-Control" which includes custom designed spools for each individual function along with "swing cushioning" valve for zero-wag swing control. Basic control valve has an open center parallel circuit for all functions.

### Pilot Backhoe Control Valve

Six, seven, or eight spool sectional closed center control valve. Features "Pro-Control" which includes custom designed spools for each individual function along with "swing cushioning" valve for zero-wag swing control. Basic control valve is closed center, with circuits in parallel with a post-compensated, flow sharing feature for simultaneous operation of all circuits.

### Unidirectional Auxiliary Hydraulics

Unidirectional hydraulic valve is equipped with an adjustable LS relief valve to control attachment pressure and a 6 position flow control selector for 6 detented, distinct flow settings.

Actuation	
Manual backhoe controls	Cab floor pedal
Pilot controls	Left hand joystick

## OPERATOR ENVIRONMENT

ROPS/FOPS canopy
Key start
Hydrostatic steering
Vinyl mechanical suspension seat w/180° swivel
Seat turn around
Electronic hand and foot throttles
Ergonomic loader control lever w/push-button activation of differential lock and transmission de-clutch
Backhoe foot-swing w/3 lever control
(2) Accessory power plugs (30 amp)
Anti-vandalism covers (canopy only)
Cup holder
Coat hook w/tether strap (cab only)
Interior rearview mirror
2 in (51 mm) retractable seat belt
Storage compartment w/lid
Left side storage tray

## INSTRUMENTATION

Vehicle Control Module w/menu driven options and onboard diagnostics
Foot throttle sensitivity
Cold weather idle settings
Maintenance settings
Gauges
Engine water temperature
Converter oil temperature
Fuel
Tachometer/hourmeter
Voltmeter
Warning lights
Air cleaner restriction
Alternator
A/C high pressure
Cold start
Engine oil pressure
Hydraulic oil filter bypass
Parking brake
Low fuel
Audible alarms w/diagnostics
Coolant temperature
Engine oil pressure
Parking brake engagement
Shuttle engagement/seat position
Backup alarm
Horn - dual switched front & rear

## TURNING DIAMETER

2WD	
Brakes on	10 ft 7.6 in (3.24 m)
Brakes off	12 ft 4 in (3.76 m)
4WD – engaged	
Brakes on	11 ft 0.3 in (3.36 m)
Brakes off	14 ft 1.7 in (4.31 m)
4WD – disengaged	
Brakes on	10 ft 11.9 in (3.35 m)
Brakes off	12 ft 7.6 in (3.85 m)

NOTE: Turning diameter dimensions curb to curb w/17.5L x 24 tires.

## OPERATING WEIGHTS

### Configuration 1 - SAE Transport

82 in (2.08 m) LL bucket, 4WD, 19.5L x 24 rear tires, standard dipper, 24 in. HD bucket, flip stabilizer pads, ROPS cab, non-suspension seat, dual battery, no operator.  
16,239 lb (7366 kg)

### Configuration 2 - SAE Transport

82 in (2.08 m) loader bucket, 4WD, 19.5L x 24 rear tires, extendahoe, 24 in. HD bucket, flip stabilizer pad, 700 lb CWT, ROPS cab, cloth seat, dual battery, mechanical backhoe coupler, no operator, power synchro-transmission.  
17,226 lb (7814 kg)

### Add-on weights

Cab (over canopy)	+0 lb (0 kg)
Counterweights	+700 lb (318 kg)
Extendahoe®	+286 lb (130 kg)
4WD w/driveshaft guard	+283 lb (128 kg)

## SERVICE CAPACITIES

Fuel tank	42 gal (159L)
Hydraulic system	
Total	126 qt (119.2 L)
w/Extendahoe®	132 qt (124.9 L)
Reservoir w/filter	58 qt (54.5 L)
Reservoir w/o filter	56 qt (52.6 L)
Transmission - Total System	
2WD Standard	18 qt (17 L)
2WD Powershift S-Type	23 qt (21.7 L)
4WD Standard	21 qt (19.4 L)
4WD Powershift S-Type	22 qt (20.7 L)
4WD Powershift H-Type	19 qt (18 L)
4WD Front axle	
Differential	8.1 qt (7.7 L)
Planetaries (each)	0.5 qt (0.5 L)
Rear axle	
Differential & Planetaries	14.4 qt (13.6 L)
Engine oil w/filter	14.4 qt (13.6 L)
Cooling system	
w/heater	19 qt (18 L)
w/o heater	18.3 qt (17.3 L)
Window washer reservoir	3.0 qt (2.8 L)

## LOADER

Single-lever control for lift and tilt			
Positive hold float			
Return-to-dig			
Automatic self-leveling			
In-line, reverse linkage			
Dual parallel dump cylinders			
Clutch disconnect button on loader control and shift levers			
Bucket position indicator			
<b>Loader Bucket Sizes</b>			
Width	Weight	Struck	Heaped
Long Lip Bucket			
82 in w/o bolt-on edge / 93 w/bolt-on edge			
82 in (2.08 m)	664 lb (392 kg)	0.88 yd³ (0.67 m³)	1.01 yd³ (0.77 m³)
93 in (2.36 m)	933 lb* (423 kg)	1.07 yd³ (0.82 m³)	1.25 yd³ (0.96 m³)
4 in 1 Bucket w/bolt-on edge			
82 in (2.08 m)	1,451 lb* (658 kg)	0.85 yd³ (0.65 m³)	1.04 yd³ (0.80 m³)

NOTE: \*Weight of 4 in 1 bucket includes edges, cylinders, and tubelines.

## BACKHOE

Over center design, Fabricated “S” boom		
Pro Control System		
17, 940 lb-ft (24 370 N-m) swing torque		
Case attachment coupler		
Foot-swing w/3 lever control		
Wing stabilizers w/cleated dirt pad		
<b>Backhoe Bucket Sizes</b>		
Width	Weight	Heaped
Universal Buckets		
12 in (305 mm)	295 lb (134 kg)	3.40 ft³ (0.10 m³)
18 in (457 mm)	356 lb (162 kg)	5.30 ft³ (0.15 m³)
24 in (610 mm)	427 lb (194 kg)	7.70 ft³ (0.22 m³)
30 in (762 mm)	489 lb (222 kg)	10.20 ft³ (0.29 m³)
36 in (914 mm)	552 lb (251 kg)	12.70 ft³ (0.36 m³)
High Capacity Buckets		
24 in (610 mm)	447 lb (203 kg)	8.50 ft³ (0.24 m³)
30 in (762 mm)	502 lb (228 kg)	10.60 ft³ (0.30 m³)

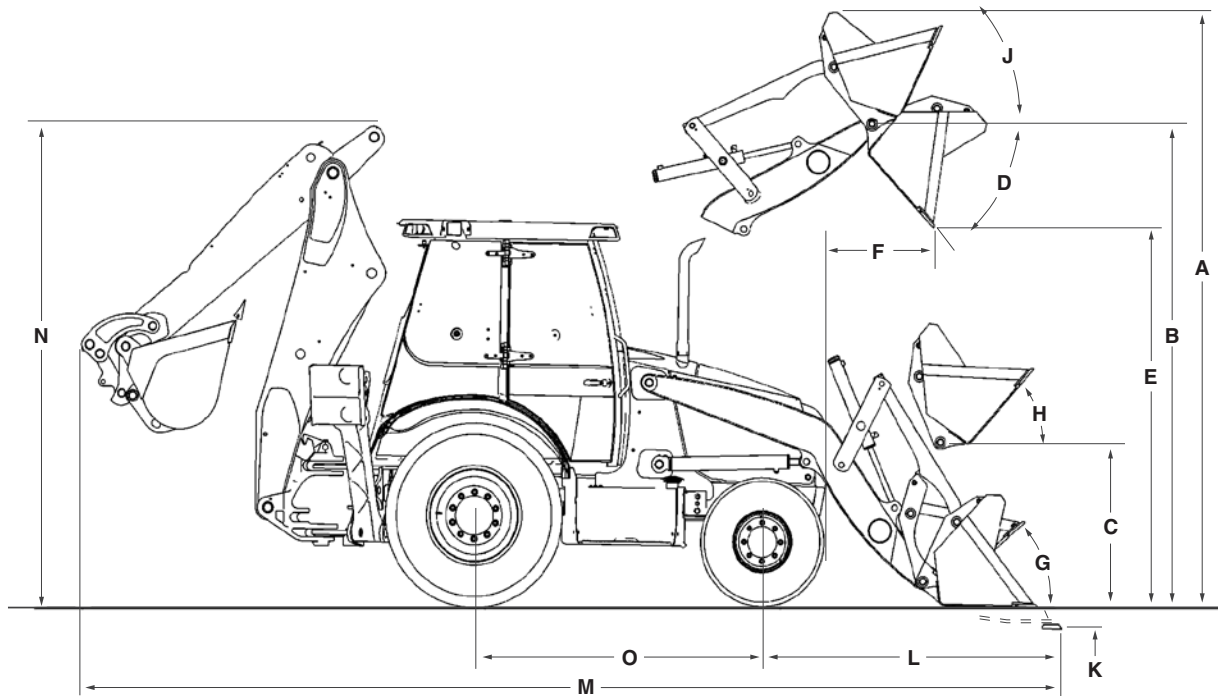

## LOADER DIMENSIONS

	Long Lip Bucket*	4 IN 1® Bucket
<b>A.</b> Overall operating height – fully raised	13 ft 8.7 in (4.18 m)	13 ft 7.8 in (4.16 m)
Height to –		
<b>B.</b> Bucket hinge pin fully raised	11 ft 2.5 in (3.42 m)	11 ft 2.5 in (3.42 m)
<b>C.</b> Bucket hinge pin @ SAE carry	13.6 in (345 mm)	13.6 in (345 mm)
<b>D.</b> Dump angle @ full height	47°	47°
<b>E.</b> Dump clearance @ full height, 45° dump –		
Bucket	8 ft 9.9 in (2.69 m)	8 ft 10.9 in (2.71 m)
Clam open	NA	9 ft 8.3 in (2.96 m)
<b>F.</b> Dump reach @ full height, 45° dump –		
Bucket	31.5 in (801 mm)	29.1 in (738 mm)
Clam open	NA	15.3 in (388 mm)
Bucket rollback –		
<b>G.</b> @ groundline	42°	42°
<b>H.</b> @ SAE carry	42°	42°
<b>J.</b> @ full height	Adjustable	Adjustable
<b>K.</b> Digging depth below grade –		
Bucket flat	6.1 in (155 mm)	4.8 in (122 mm)
Clam open (dozing)	NA	4.1 in (103 mm)
<b>L.</b> Reach from front axle centerline – bucket on ground	6 ft 8.8 in (2.05 m)	6 ft 0.7 in (2.03 m)
Lift capacity to full height (calculated values)	7,044 lb (3195 kg)	6,703 lb (3040 kg)
Breakout force (calculated values–		
Lift cylinders	9,833 lbf (4460 daN)	9,610 lbf (4359 daN)
Dump cylinders	10,947 lbf (4965 daN)	11,658 lbf (5288 daN)
Bucket cutting edge width	82.5 in (2.09 m)	82 in (2.08 m)
Maximum grading angle	114°	114°
Maximum clam opening	NA	38.3 in (972 mm)
Moldboard height	NA	36.8 in (934 mm)
Raising time to full height – Manual/Pilot controls	3.4/3.6 sec	3.4/3.6 sec
Bucket dumping time	1.8/2.0 sec	1.8/2.0 sec
Lowering time –		
Power down	2.5/2.6 sec	2.5/2.6 sec
Return-to-dig	3.6/2.8 sec	3.6/2.8 sec
Clam –		
Open time	NA	1.3 sec
Close time	NA	1.1 sec

NOTE: Loader dimensions taken with 4WD, 19.5L x 24 rear tires..

## DIMENSIONS

	2WD w/17.5L x 24 rear tires	4WD w/ 19.5L x 24 rear tires
<b>M. Overall transport length –</b>		
Long Lip bucket w/Quick Coupler	23 ft 5 in (7.14 m)	23 ft 3.6 in (7.10 m)
4in1® bucket w/Quick Coupler	23 ft 2.5 in (7.07 m)	23 ft 1.3 in (7.04 m)
Long Lip bucket w/Straight Links	23 ft 5.7 in (7.15 m)	23 ft 4.3 in (7.12 m)
4in1® bucket w/Straight Links	23 ft 3.1 in (7.09 m)	23 ft 1.9 in (7.06 m)
Overall transport width	7 ft 1.5 in (2.17 m)	7 ft 1.5 in (2.17 m)
Height –		
To top of canopy	8 ft 8.1 in (2.64 m)	8 ft 8.8 in (2.66 m)
To top of cab	8 ft 9.4 in (2.68 m)	8 ft 11 in (2.72 m)
To top of exhaust stack	8 ft 5.4 in (2.58 m)	8 ft 6.9 in (2.62 m)
<b>N. Transport</b>	10 ft 9.9 in (3.29 m)	11 ft 0.5 in (3.37 m)
Ground clearance at backhoe frame	12 in (304 mm)	15 in (381 mm)
Angle of departure	15.3°	19°
Front wheel tread		
11L x 16	67.5 in (1.72 m)	
12 x 16.5	67.7 in (1.72 m)	
19.5 x 24	61.2 in (1.55 m)	
17.5L x 24	63.1 in (1.60 m)	
Width across tires		
11L x 16	79.3 in (2.02 m)	
12 x 16.5	81.1 in (2.06 m)	
19.5 x 24	81.4 in (2.07 m)	
17.5L x 24	81.7 in (2.07 m)	
	<b>2WD</b>	<b>4WD</b>
<b>O. Wheelbase</b>		
19.5L x 24	84 in (2.13 m)	84.5 in (2.15 m)
17.5L x 24	84 in (2.13 m)	84.5 in (2.15 m)

## CYLINDERS

	Bore Diameter	Rod Diameter	Stroke	Closed Length
<b>Loader</b>				
Lift (2)	3.25 in (82.6 mm)	1.75 in (44.5 mm)	28.86 in (733 mm)	42.95 in (1062 mm)
Bucket (2)	3.0 in (76.2 mm)	1.5 in (38.1 mm)	20.33 in (516.5 mm)	29.9 in (759.5 mm)
4 IN 1® clam (2)	3.0 in (76.2 mm)	1.75 in (44.5 mm)	9.08 in (230.6 mm)	19.62 in (498.3 mm)
<b>Backhoe</b>				
Boom	5.0 in (127 mm)	2.5 in (63.5 mm)	38.25 in (971.6 mm)	52.82 in (1341.6 mm)
Dipperstick	4.75 in (120.7 mm)	2.5 in (63.5 mm)	25.14 in (628.5 mm)	39.65 in (1007 mm)
Bucket	3.5 in (88.9 mm)	2.5 in (63.5 mm)	35.35 in (897.9 mm)	48.17 in (1223.6 mm)
Extendahoe®	3.0 in (76.2 mm)	1.75 in (44.5 mm)	42.05 in (1068 mm)	56.22 in (1428 mm)
Swing (2)	4.0 in (101.6 mm)	2.0 in (50.8 mm)	11.5 in (292 mm)	24.44 in (620.8 mm)
Stabilizer (2)	4.5 in (114.3 mm)	2.25 in (57.2 mm)	21.437 in (542.9 mm)	33.87 in (860.2 mm)

## AXLE RATINGS

	Front - 2WD	Rear	Front - 4WD
Maximum static	70,821 lb (32 124 kg)	90,145 lb (40 889 kg)	64,613 lb (29 308 kg)
Dynamic operating	44,261 lb (20 076 kg)	56,200 lb (25 492 kg)	39,328 lb (17 839 kg)
Static operating	17,704 lb (8030 kg)	22,480 lb (10 197 kg)	15,732 lb (7136 kg)

## BACKHOE LIFT CAPACITIES

Boom Lift	Standard Backhoe		Extendahoe®			
	Standard Lift Capacity – lb (kg)	Power Lift Lift Capacity – lb (kg)	Retracted		Extended	
			Standard Lift Capacity – lb (kg)	Power Lift Lift Capacity – lb (kg)	Standard Lift Capacity – lb (kg)	Power Lift Lift Capacity – lb (kg)
+16 ft (4.87 m)	—	—	—	—	2,115 (959)	2,298 (1043)
+14 ft (4.27 m)	3,039 (1378)	3,285 (1490)	2,837 (1287)	3,083 (1398)	2,395 (1086)	2,603 (1181)
+12 ft (3.66 m)	3,413 (1548)	3,691 (1674)	3,201 (1452)	3,479 (1578)	2,536 (1151)	2,757 (1250)
+10 ft (3.05 m)	3,499 (1587)	3,784 (1716)	3,281 (1488)	3,566 (1618)	2,593 (1176)	2,818 (1278)
+8 ft (2.44 m)	3,485 (1581)	3,768 (1709)	3,263 (1480)	3,546 (1608)	2,564 (1163)	2,786 (1264)
+6 ft (1.83 m)	3,438 (1559)	3,717 (1686)	3,213 (1457)	3,492 (1584)	2,549 (1156)	2,770 (1257)
+4 ft (1.22 m)	3,374 (1530)	3,648 (1655)	3,146 (1427)	3,420 (1551)	2,521 (1144)	2,741 (1243)
+2 ft (0.61 m)	3,307 (1500)	3,575 (1622)	3,077 (1396)	3,345 (1517)	2,489 (1129)	2,706 (1227)
<b>Ground Level</b>	3,251 (1475)	3,513 (1594)	3,018 (1369)	3,280 (1488)	2,489 (1129)	2,706 (1227)
-2 ft (0.61 m)	3,201 (1452)	3,459 (1569)	2,965 (1345)	3,223 (1462)	2,466 (1118)	2,680 (1215)
-4 ft (1.22 m)	3,175 (1440)	3,430 (1556)	2,935 (1331)	3,190 (1447)	2,446 (1109)	2,659 (1206)
-6 ft (1.83 m)	3,182 (1443)	3,437 (1559)	2,938 (1333)	3,193 (1448)	2,443 (1108)	2,656 (1205)
-8 ft (2.44 m)	3,258 (1478)	3,520 (1597)	3,007 (1364)	3,269 (1483)	2,465 (1118)	2,679 (1215)
-10 ft (3.05 m)	3,441 (1561)	3,717 (1686)	3,175 (1440)	3,451 (1565)	2,530 (1148)	2,750 (1248)
-12 ft (3.66 m)	—	—	—	—	2,707 (1228)	2,943 (1335)
-14 ft (4.27 m)	—	—	—	—	3,239 (1469)	3,521 (1597)
<b>Dipper Lift</b>						
+14 ft (4.27 m)	—	—	—	—	4,281 (1942)	4,281 (1942)
+12 ft (3.66 m)	5,822 (2641)	5,822 (2641)	5,618 (2548)	5,618 (2548)	4,046 (1835)	4,046 (1835)
+10 ft (3.05 m)	5,600 (2540)	5,600 (2540)	5,399 (2449)	5,399 (2449)	3,984 (1807)	3,984 (1807)
+8 ft (2.44 m)	5,562 (2523)	5,562 (2523)	5,360 (2431)	5,360 (2431)	3,913 (1775)	3,913 (1775)
+6 ft (1.83 m)	6,236 (2829)	6,236 (2829)	6,030 (2735)	6,030 (2735)	4,166 (1889)	4,166 (1889)
+4 ft (1.22 m)	7,424 (3368)	7,424 (3368)	7,203 (3267)	7,203 (3267)	4,102 (1861)	4,102 (1861)
+2 ft (0.61 m)	—	—	—	—	4,850 (2200)	4,850 (2200)

## BACKHOE OPERATIONAL DATA

	Standard Backhoe		Extendahoe®	
			Retracted	Extended
Digging depth –				
Maximum	14 ft 5.6 in (4.41 m)		14 ft 5.6 in (4.41 m)	17 ft 11.2 in (5.47 m)
Maximum w/hi-capacity bucket	14 ft 11.9 in (4.51 m)		14 ft 11.9 in (4.51 m)	18 ft 5.5 in (5.63 m)
2 ft (610 mm) flat bottom	14 ft 4.1 in (4.37 m)		14 ft 4.1 in (4.37 m)	17 ft 9.8 in (5.43 m)
8 ft (2.44 m) flat bottom	13 ft 4 in (4.06 m)		13 ft 4 in (4.06 m)	17 ft 0.5 in (5.19 m)
Overall reach from –				
Rear axle centerline	21 ft 10.3 in (6.66 m)		21 ft 10.3 in (6.66 m)	25 ft 2.9 in (7.69 m)
Swing pivot	18 ft 2.4 in (5.55 m)		18 ft 2.4 in (5.55 m)	21 ft 7 in (6.58 m)
Loading height	12 ft 0.5 in (3.67 m)		12 ft 0.5 in (3.67 m)	14 ft 4.5 in (4.38 m)
Loading reach	4 ft 7.4 in (1.41 m)		4 ft 7.4 in (1.41 m)	7 ft 2.7 in (2.20 m)
Swing arc	180°		180°	180°
Bucket rotation –				
Straight Links	175.6°		175.6°	175.6°
Mechanical Coupler	198°		198°	198°
Hyd. Coupler - Extendahoe dipper	194.8°		194.8°	194.8°
Hyd. Coupler - Standard dipper	180°		180°	180°
Stabilizer spread – operating				
Flip pad	9 ft 3 in (2.82 m)		9 ft 3 in (2.82 m)	9 ft 3 in (2.82 m)
Cast pad	9 ft 7.2 in (2.93 m)		9 ft 7.2 in (2.93 m)	9 ft 7.2 in (2.93 m)
Digging force –				
Bucket cylinder – SAE rated 3,460 psi	13,576 lbf (60 388 N)		13,576 lbf (60 388 N)	13,576 lbf (60 388 N)
Bucket cylinder – Power Lift	14,223 lbf (63 267 N)		14,223 lbf (63 267 N)	14,223 lbf (63 267 N)
Dipper cylinder – SAE rated 3,460 psi	8,657 lbf (38 508 N)		8,657 lbf (38 508 N)	6,305 lbf (28 045 N)
Dipper cylinder – Power Lift	9,070 lbf (40 345 N)		9,070 lbf (40 345 N)	N/A
Leveling angle				
Flip pad	11.8°		11.8°	11.8°
Cast pad	12.8°		12.8°	12.8°

NOTE: Lift capacities apply straight to the rear of prime mover. 4WD with 19.5L x 24 tires equipped with 24 in (610 mm) Heavy-duty bucket and Case coupler except as noted.

## STANDARD EQUIPMENT

### OPERATOR'S COMPARTMENT

See page 2

### ENGINE

Case 445TA/E3 non-EGR turbocharged diesel  
Emissions compliant  
Full flow engine oil filter  
Air cleaner - replaceable dry type with radial seal  
Aspirated air cleaner  
Muffler, non spark arresting  
Fuel filter w/water trap  
Self-adjusting belt tensioner  
Balanced engine  
High Pressure Common Rail computer controlled injection with diagnostic features  
Electronic throttles (foot and rotary hand)  
Antifreeze to -34°F (-37°C)  
Radiator with de-aeration bottle

### LOADER

See page 2

### BACKHOE

See page 2

## OPTIONAL EQUIPMENT

### OPERATOR'S COMPARTMENT

Ride Control  
Comfort Steering with momentary latching switch, two speed steering pump and 3rd/4th gear cutout.  
ROPS/FOPS certified protective cab w/rear wipers and floor mat  
Cab Convenience Package containing:  
Pull-down sunvisor  
Window washer, front and rear  
Left-hand storage tray  
Deluxe interior package  
Tilt steering column  
Sound Reduction Package for cab models - levels reduced to 72 dB (A)  
Right-hand threshold storage box  
Viscous Fan  
Air-conditioning for cab models  
Mechanical suspension seat with flip-up arm rests, 180° swivel, cloth or vinyl, adjustable seat and weight, backrest angle, lumbar and cushion angle  
Air Ride suspension seat with flip-up arm rests, 180° swivel  
Electric height adjustment, adjustable back rest and lumbar support - cab units cloth, canopy units vinyl  
Pull-down sunvisor for canopy models  
Radio, AM/FM Stereo/WB, MP3 aux input (cab models)

### POWERTRAIN

Standard Powershuttle, 4F-4R Power Shuttle Synchronesh transmission  
Front Axle  
2WD heavy-duty front axle w/ 11L x 16 tires  
4WD heavy-duty mechanically driven front axle w/ 12 x 16.5 tires and drive shaft guard  
Rear Axle  
2/4WD heavy-duty outboard planetary drive w/ 17.5L x 24, 10PR (R4) tires  
11.8 in (300 mm) torque converter  
On-the-Go electric 4WD control  
Electric F/R shuttle control  
Electric differential lock control, push button  
Park Brake, spring applied, hydraulic release (SAHR)

### HYDRAULICS

Variable Displacement Axial Piston Pump:  
Maximum Loader Capacity:  
40 GPM @ 2340 psi (151.4 lpm @ 161 bar)  
Loader Torque Regulation:  
27.4 GPM @ 3450 psi (103.4 lpm @ 238 bar)  
Maximum Backhoe Capacity:  
40 GPM @ 3100 psi (151.4 lpm @ 214 bar)

### OPERATOR'S COMPARTMENT (continued)

3 in (75 mm) seat belt for mechanical and air suspension seat

### ENGINE

Cold Weather Starting Aid - grid heater w/ dual 12 volt batteries

### LOADER

Auxiliary hydraulics for loader-mounted equipment with thumb-operated proportional control  
Hydraulic front quick coupler  
Bolt-on cutting edges  
Loader linkage w/o loader bucket  
Tool portfolio of additional attachments  
Buckets (see page 2)

### BACKHOE

Auxiliary hydraulics with flow from 0 to 36 gal/min (0 to 136 L/min)  
Extendahoe®  
Power Lift  
Two-lever control (backhoe or Extendahoe)  
Pilot operated control system  
Fingertip proportional electrohydraulic stabilizer controls  
Thumb-operated proportional electrohydraulic Extendahoe® control  
Thumb-operated horn button  
Thumb-operated auxiliary hydraulic control  
Infinitely adjustable towers  
In-cab switchable "excavator to backhoe" control pattern change

### HYDRAULICS (continued)

Backhoe Torque Regulation:  
35 GPM @ 3450 psi (132 lpm @ 238 bar)  
Heavy-duty oil cooler  
7 micron, spin-on oil filter

### OTHER

Forward tilt engine hood  
Replaceable, molded front bumpers  
Front/rear tie downs  
Reflective logos  
Lights - Cab and Canopy  
(2) Rear tail/stop  
(2) Front flashers/turn  
(2) Rear flashers/turn  
Cab only  
2 front driving lights (55 w)  
2 front, 2 side (left & right) & 4 rear adjustable halogen work lights (55 w)  
Canopy only  
2 front driving lights (55 w)  
2 side (left & right) & 2 rear adjustable halogen work lights (55 w)

### BACKHOE (continued)

Flip over stabilizer pads  
Cemetery Pads  
Hydraulic bucket quick coupler  
Bucket retrofit kit  
Buckets (see page 2)

### POWERTRAIN

Powershift S-Type transmission, 4F-3R electronic transmission controller and kick down in loader control lever (2WD or 4WD)  
Powershift H-Type transmission, 4F-3R hydraulic clutch shifting with auto function  
Rear axle heavy-duty outboard planetary drive w/ 19.5L x 24 tires either 2WD or 4WD

### HYDRAULICS

Auxiliary backhoe uni-directional hydraulics  
Auxiliary backhoe bi-directional hydraulics  
Hand lever operated for manual controls  
Button operated for pilot controls

### OTHER

11 x 16 or 12 x 16.5 front tires  
17.5L x 24 or 19.5L x 24 rear tires  
Front counterweights - 700 and 1,100 lb (318 and 500 kg)



NOTE: All specifications are stated in accordance with SAE Standards or Recommended Practices, where applicable.

NOTE: All engines meet current EPA emissions requirements.

IMPORTANT: Case Construction Equipment Inc. reserves the right to change these specifications without notice and without incurring any obligation relating to such change. Case Construction Equipment Inc. does not warrant the safety or reliability of attachments from other manufacturers.

Case is a registered trademark of CNH America LLC. Any trademarks referred to herein, in association with goods and/or services of companies other than CNH America LLC, are the property of those respective companies.

